

# LONGKING 龙工

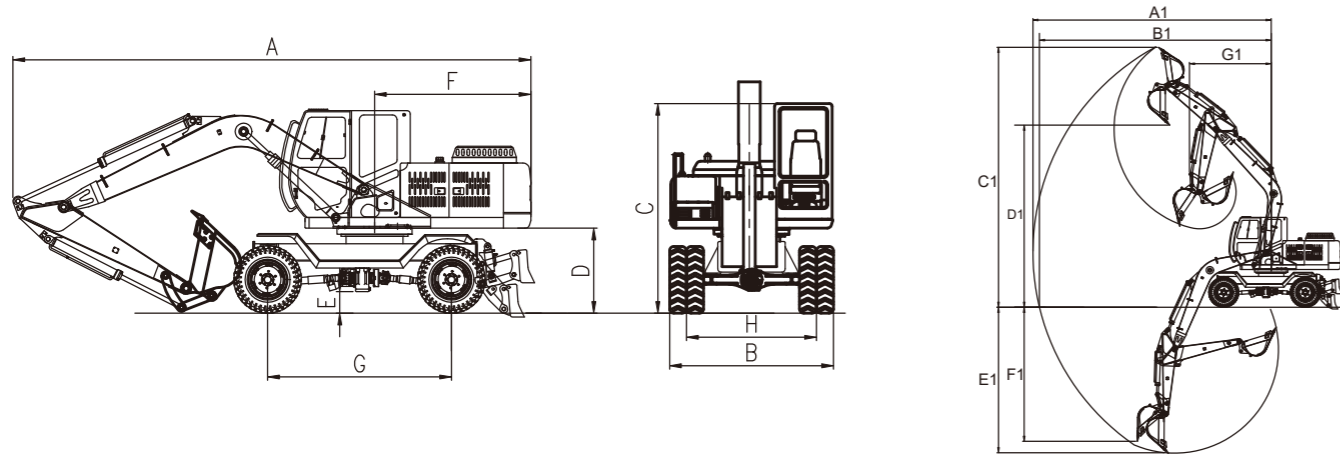

## TECHNICAL PARAMETERS

| Name              |                                  | Data               |
|-------------------|----------------------------------|--------------------|
| Basic             | Operating weight                 | 22500 kg           |
|                   | Boom length                      | 5675 mm            |
|                   | Arm length                       | 2920 mm            |
|                   | Standard bucket                  | 1.0 m <sup>3</sup> |
|                   | Max.Travel speed                 | 25 km/h            |
|                   | Max.Swing speed                  | 13.5 rpm           |
|                   | Grade ability                    | 30°(58%)           |
|                   | Tire type                        | 1100-20            |
|                   | Max.Traction force               | 90 kN              |
| Engine            | Engine model                     | 6BTAA5.9-C150-II   |
|                   | Rated power                      | 112 kW/1950 rpm    |
|                   | Displacement                     | 5.9 L              |
|                   | Fuel tank                        | 300 L              |
|                   | Max.Torque                       | 614/1500 N.m/rpm   |
| Hydraulic         | Max.Flow(total)                  | 280×2 L/min        |
|                   | Max.Working pressure             | 35 MPa             |
|                   | Max.Digging force                | 130 kN             |
|                   | Hrdraulic oil tank               | 250 L              |
| Working Range     | A1 Max.Digging reach             | 9970 mm            |
|                   | B1 Max.Ground digging reach      | 9750 mm            |
|                   | C1 Max.Digging height            | 9850 mm            |
|                   | D1 Max.Dumping height            | 6930 mm            |
|                   | E1 Max.Digging depth             | 6420 mm            |
|                   | F1 Max.Vertical digging depth    | 4370 mm            |
|                   | G1 Min. Working radius           | 3645 mm            |
| Overall Dimension | Transport demission (A×B×C)      | 9770×2540×3330 mm  |
|                   | D Counterweight ground clearance | 1300 mm            |
|                   | E Min. Ground clearance          | 350 mm             |
|                   | F Tail swing radius              | 3500 mm            |
|                   | G Axle base                      | 3300 mm            |
|                   | H Wheel base                     | 1920 mm            |

## CONFIGURATION

| Name         | Type                            |
|--------------|---------------------------------|
| Engine       | Cummins direct injection engine |
| Main valve   | Multiple unit                   |
| Main pump    | Piston type                     |
| Swing motor  | Piston type                     |
| Gearbox      | Hydraulic                       |
| Travel motor | Piston type                     |

## OPTIONAL

|                  |
|------------------|
| Custom bucket    |
| Hydraulic hammer |
| Quick coupler    |
| Hydraulic clamp  |
| Magnetic chuck   |

## PRODUCT FEATURES

|  |
|--|
| Cummins TDI 4-cylinder Engine. Strong Power, Fuel-efficient                          |
| Three-stage Air & Fuel Filtering System  |
| Charge air Cooling System with Parallel Radiator                                     |
| Advanced Hydraulic System with Function of Interflow & Re-activation, Swing Priority |
| 8 inch LCD Display with Multi Purpose  |
| Camfortable ROPS Cabin with 2.7m <sup>3</sup> Operational Space                      |
| No Frame Cab Glasses to Enlarge Operation Field of View                              |
| Heavy-duty Working Device with High Strength Low Alloyed Steels                      |



# CDM6225W WHEEL EXCAVATOR

Efficiency Rules the Future

The following blank can be used for notes or comments.

For more information on Lonking products,  
Please contact our local agent:

Lonking, Lonking CDM Series and their respective logos, as well as corporate identity in this leaflet are trademarks of Lonking Holdings Ltd., and may not be used without written permission.

2023/03

Specifications and design are subject to change without prior notice. Machines shown may not include optional accessories.

LONGKING (FU JIAN) INTERNATIONAL TRADE CO., LTD.

**LONGKING HOLDINGS LIMITED**

Add: 26 Minyi Road, Xinqiao, Songjiang Industrial Zone, Shanghai

Tel: +86-21-3760 2242 E-mail: export@lonking.cn

<http://www.lonkinggroup.com>

|                   |                   |
|-------------------|-------------------|
| OPERATING WEIGHT: | 22500kg           |
| ENGINE POWER:     | 112kW             |
| BUCKET CAPACITY:  | 1.0m <sup>3</sup> |
| TRAVEL SPEED:     | 5-25km/h          |